

Gaskets

Gaskets

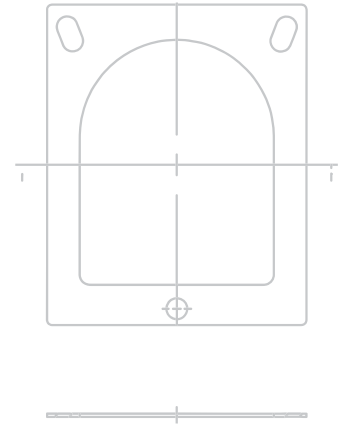

Gaskets

Are used to create a static seal between two or more mating surfaces to prevent leakage from or into joined objects under operating conditions.

Types

Tongue and Groove
 Flange
 Lap Joint and Slip-on
 Ring Joint

Materials

- Nitrile
- Paper
- Felt
- Fluorocarbon
- Plastic Polymer
- Fiberglass
- Cork
- Neoprene
- Metal

Contact J Royal for mor material options.



Why Industry Leaders Rely on J Royal

GLOBAL REACH – LOCAL RELATIONSHIPS

For over 60 years, J Royal has provided quality sealing solutions to a diverse group of markets. Our knowledgeable staff is highly regarded in the industry for its ability to consistently provide optimal design recommendations and its commitment to building long-standing, prosperous relationships. What sets J Royal apart is its broad product base, unbeatable product knowledge, extensive logistics and distribution capabilities, and progressive engineering skills, all supported by global resources.

THE J ROYAL ADVANTAGE

Our products fit nearly every category:

- O-Rings
- Wipers
- Precision Metal Products
- Gaskets
- Machined Plastic Parts
- Compounds
- Custom Moloded Parts
- Piston Seals
- Rod Seals
- Standard & Custom Seals

PARTNER OF CHOICE

J Royal has the team to not just meet your needs but surpass your expectations. From local sales support and design assistance to quotation and quality assurance, we are ready to support you as an integral member of your supply chain.



NORTH CAROLINA
CORPORATE OFFICE
2441 Salem Park Drive
Winston-Salem, NC 27127
336.794.0400 PHONE
800.626.8807 TOLL FREE
336.794.0401 FAX

ALABAMA
180 Twin Creek Drive
Talladega, AL 36078
336.794.0400 PHONE
800.626.8807 TOLL FREE
336.794.0401 FAX

© 2016, J Royal Co., Inc. Rev 2.16

LIMITED WARRANTY J Royal Co. ("Seller") warrants that its products ("Goods") will perform in accordance with their specifications; that the goods will be free from manufacturing defects for a period of twelve (12) months from the date of delivery of the goods to Buyer; and that the goods will be as specified by Buyer in the purchase order. Seller should have the right to elect to either refund the purchase price for any defective goods or replace any defective goods, provided that the goods were used in the manner for which they were manufactured. Seller does not warrant that the goods are fit for any particular purpose. Seller should have no obligation to refund the purchase price or replace goods that are rendered defective by a Buyer or a third party after they leave Seller's place of shipment.

LIMITED LIABILITY Seller's liability for its goods is limited to their terms set forth in Seller's express warranty set for above, in no event shall Seller's liability exceed the total purchase order price. Seller is not assuming any liability for any indirect, collateral, special, incidental or consequential losses or damages suffered by Buyer, or by any end-user or other third party, including but not limited to, lost profits, loss of business reputation and/or lost business opportunity, for any possible cause of action or claim arising out of or related to the goods sold to Buyer, even if Seller has been advised of the possibility of such loss or damage.